

Ezy Reflector PE Beam Manual.

● Feature

- Strong resistance to the sunlight interference, it reaches 100,000Lux.
- Advanced optical technology for long distance detection
- First-class electromagnetic compatibility, strong resistance to the electromagnetic interference
- Short-circuit protection, output protection, and reverse polarity protection for easier wiring

● Parameter Description

Distance	10M
light source	Red light 660nm
Working Voltage	DC/AC 12-24V
Current	≤40mA
IP	IP67
Relay contact	DC 1A 240VAC/30VDC AC 3A 30VDC/250VAC
Operating	-25~55°C
Power-on delay	200ms
Reaction time	≤30ms
Repeatability	10%
Output indication	Green light for power indicator, red light for output indication
Protective	Short circuit protection, output protection, reverse polarity protection
Housing material	PMMA ABS characteristic plastic. lens PMMA
Wiring	Standard 2-meter wire output or 6-meter output
Accessories	1 * metal bracket, 2 *screws, 2* nuts

● Wiring diagram

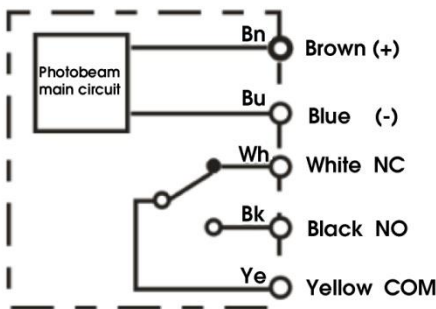

● Mechanical dimension drawing (mm)

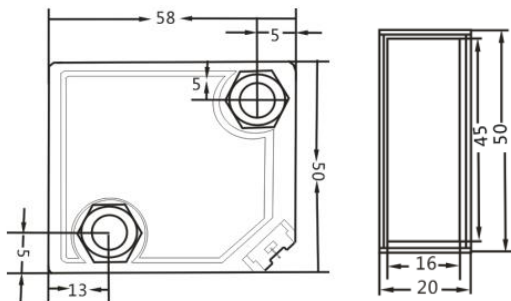

● Bracket diagram (mm)

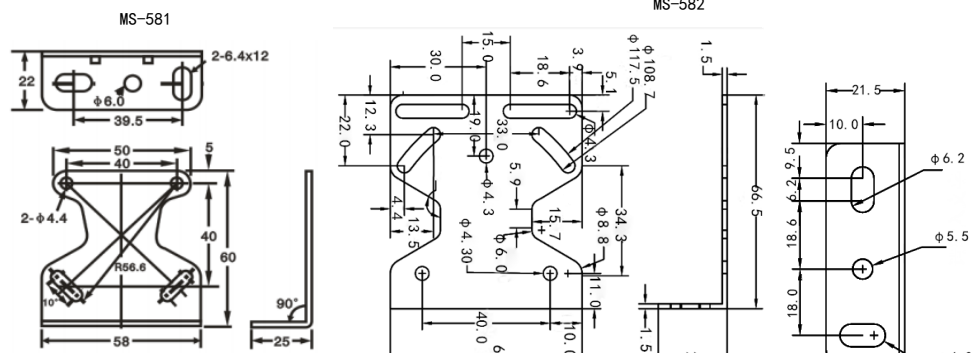

Reflector Chart (mm)

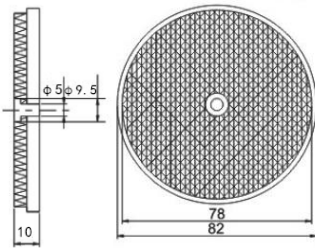

RF-10.1

Attention

1. This product cannot be used when the power is turned on (within 200ms).
2. When using the reflector type photoelectric switch, if the object to be detected is a smooth flat glass or mirror, it is necessary to select a photoelectric switch with a polarization function.
3. Be sure to connect properly when connecting the circuit to avoid damage to the product.

Maintenance and repair

To make the photoelectric switch work stably for a long time, as with the general controller, please perform the following periodic inspections:

1. Check whether the installation position of the detecting object and the photoelectric switch is offset, loose or deformed.
2. Check wiring, connection parts for looseness, poor contact, and disconnection.
3. Check the test surface for any deposits such as metal dust.
4. Check the use temperature and ambient conditions for abnormalities.