

SINGLE INFRARED BEAM SAFETY SENSOR

HW-08

General

The package contains one infrared transmitter photocell and one infrared receiver photocell. Photocells are housed inside a high-power infrared filter plastic box.

The photocell can be welded or screwed to a post or mounted directly to a wall using the plugs and screws provided. The connecting cables can be inserted through the bottom of the box.

Please read the manual carefully before installation.

The photocell is without any fuse, so please make sure the power is off before installation.

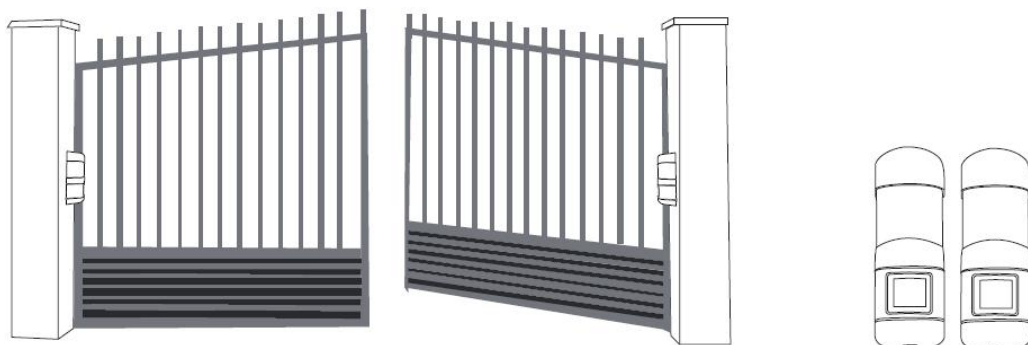

Content of the package:

- N.1 Transmitter Photocell
- N.1 Receiver Photocell
- N.6 Self Tapping Screws
- N.6 Expansion Plugs
- N.2 Post Screws
- N.1 User Manual

TECHNICAL DATA:

- 1.Power Supply: AC/DC 12-24V
- 2.Working Current: Transmitter: $\leq 30\text{mA}$; Receiver: $\leq 50\text{mA}$
- 3.Infrared Wavelength: 890nm
- 4.Operating Distance: $\geq 12\text{M}$
- 5.Adjusting angle of PCB: $\pm 90^\circ$
- 6.Receiver Relay Contact Output: Max. 1A at 24V DC
- 7.Operating Temperature: $-20^\circ\text{C}\sim+60^\circ\text{C}$
- 8.N.C. Or N.O. Can Be Set Through Jumper on Receiver Photocell
- 9.Protection Rating: IP54

PRODUCT OVERVIEW:

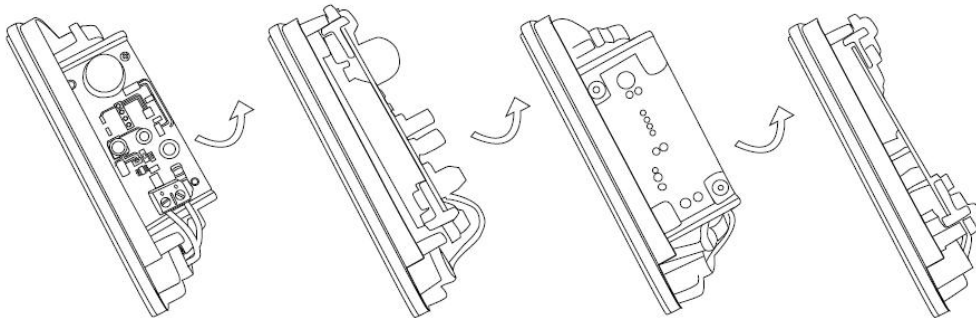

INSTALLATION INSTRUCTION:

The photocells should be installed at height of more than 20cm above the ground. And the distance between transmitter and receiver should be more than 50cm.

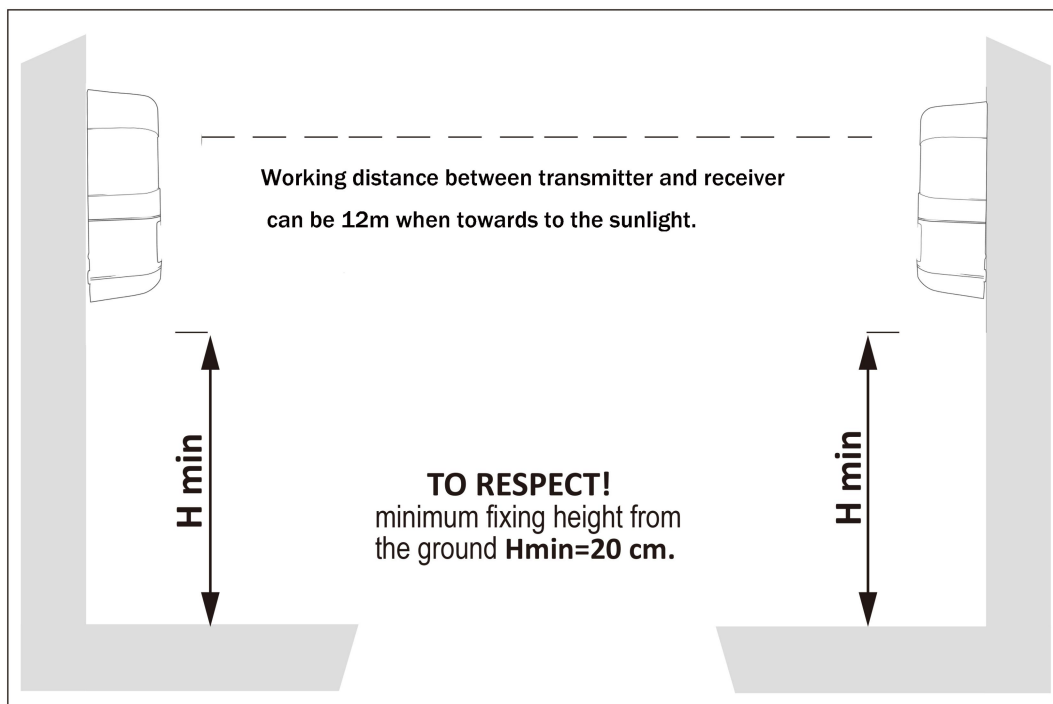

The user should install the photocells on the back of the direct sunlight or other strong light source to keep it working steadily.

Avoid installing other infrared transmitter within effective distance of receiver.

Do not use this photocell on installations in which two or more photocells are installed in parallel and close together.

If the end users need to install other photocells in one same straight line, the receivers could be installed in the two ends and the emitters could be back-to-back installed

Stable installation could avoid the signal of emitter and receiver skewing due to lightly vibrate and the malfunction.

When the product is installed in some place with angle, end user could adjust the PCB to make the installation better.

Connecting power after checking no error of connecting lines, emitter LED lights, keep the CAP of emitter and receiver align, receiver LED off; When they are not align, receiver LED on.

Installation

1. Open the package, take out the supplied accessories.
2. Use the supplied base location map as a template to mark out the three screw holes for fixing the photocell.
3. Drill the holes and fix expansion plugs.
4. Open the photocell box and connect the wires to the terminal block following the wiring instructions given below.
5. Screw the box to the wall using the screws and plugs supplied.
6. Adjust the angle PCB of photocell to the most suitable position, then fix the screw tightly.
7. Put the top cover back to the base and fix the screw tightly.

Handle the circuit board and components with care. Do not press board components. Do not use tools. Otherwise it may cause damage to the photocells.

